

## MILLING SPINDLE

With Automatic Tool Change

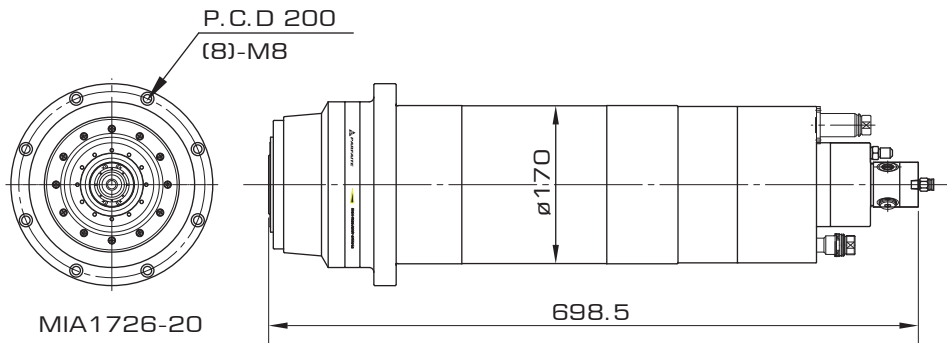

MIA1726-20

## TORQUE AND POWER CURVE

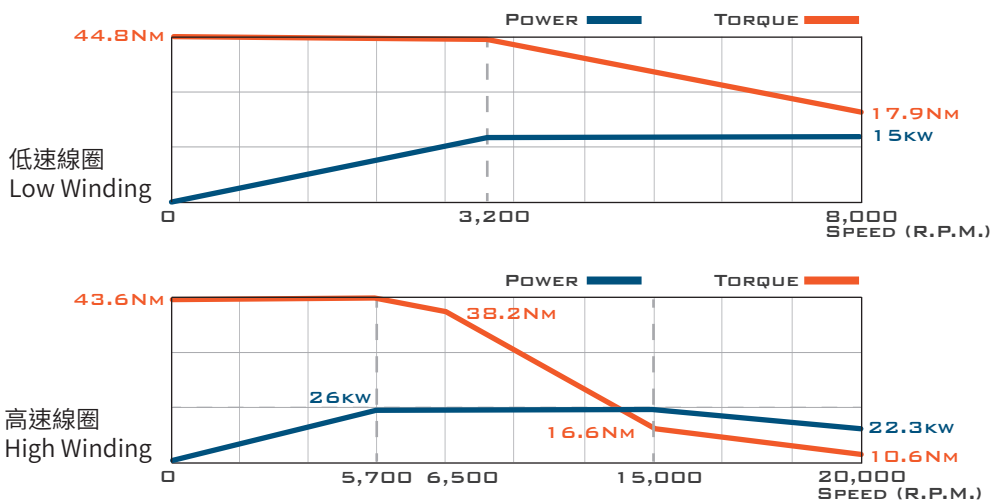

## SPECIFICATIONS (FANUC)

項目	內容
安裝方式 Installation Position	立式 / 臥式 Vert / Horiz
轉速 Speed / rpm	Max. 20,000 rpm
頻率 Frequency / Hz	667 Hz
軸承 Ball Type	陶瓷珠 Ceramic Ball
軸承潤滑方式 Bearing Lubrication	油脂 Grease
電壓 Voltage / V	220 V
功率 Power / KW	26 Kw
扭力 Torque / Nm	43.6 Nm
刀把 / 筒夾 Tool Holder / Collet	HSK63A / BT40 / BTT40
冷卻方式 Cooling Type	水冷 Water
主體外徑 D / mm	170 mm
主軸全長 L / mm	647 mm / 698.5 mm (CTS)
重量 Weight / Kg	90 Kg

Remarks 備註 : (CTS) 有中心出水 Coolant Through Spindle