

## MILLING SPINDLE

With Automatic Tool Change

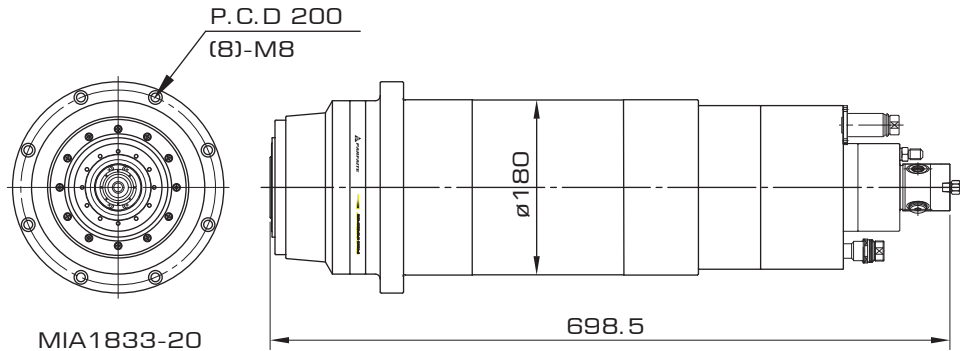

## TORQUE AND POWER CURVE

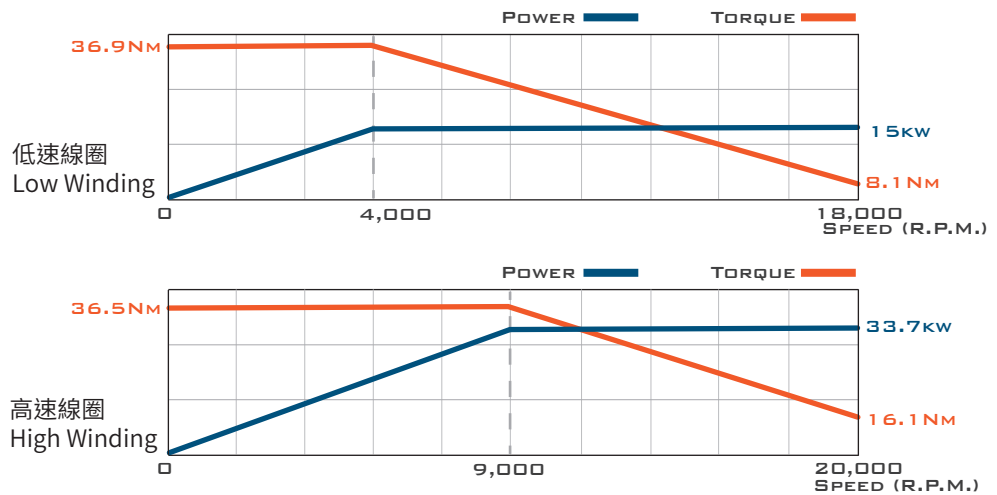

## SPECIFICATIONS (ATE)

項目	內容
安裝方式 Installation Position	立式 / 臥式 Vert / Horiz
轉速 Speed / rpm	Max. 20,000 rpm
頻率 Frequency / Hz	667 Hz
軸承 Ball Type	陶瓷珠 Ceramic Ball
軸承潤滑方式 Bearing Lubrication	油脂 Grease
電壓 Voltage / V	380 V
功率 Power / KW	33.7 Kw
扭力 Torque / Nm	36.5 Nm
刀把 / 筒夾 Tool Holder / Collet	HSK63A / BT40 / BTT40
冷卻方式 Cooling Type	水冷 Water
主體外徑 D / mm	180 mm
主軸全長 L / mm	647 mm / 698.5 mm (CTS)
重量 Weight / Kg	95 Kg

Remarks 備註: (CTS) 有中心出水 Coolant Through Spindle